

Specification

750x900 mm Platform
 Front Access
 Rated load 225 kg
 Speed 0.1 m/s
 Supply: Single phase 220 VAC
 Carriage Colour: RAL 7035
 Rail finish anodized aluminum
 Wall Mounted
 20-50 degree stair angle
 Electrical components rated to IP65
 Control units at both landings incorporate
 Up/Down, barrier and platform position
 constant pressure controls.

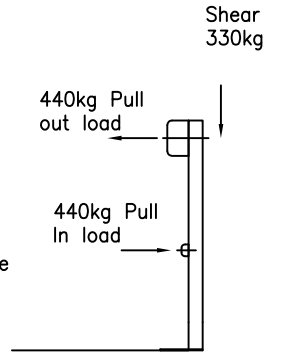

Notes

FIXING RAIL REACTIONS

Others to ensure that the fixing wall can withstand the loads from the platform lift.
 Others to supply a 13 amp RCD protected socket outlet at the top landing below our control unit for the platform lift supply.
 All wiring to the control units to be surface mounted.

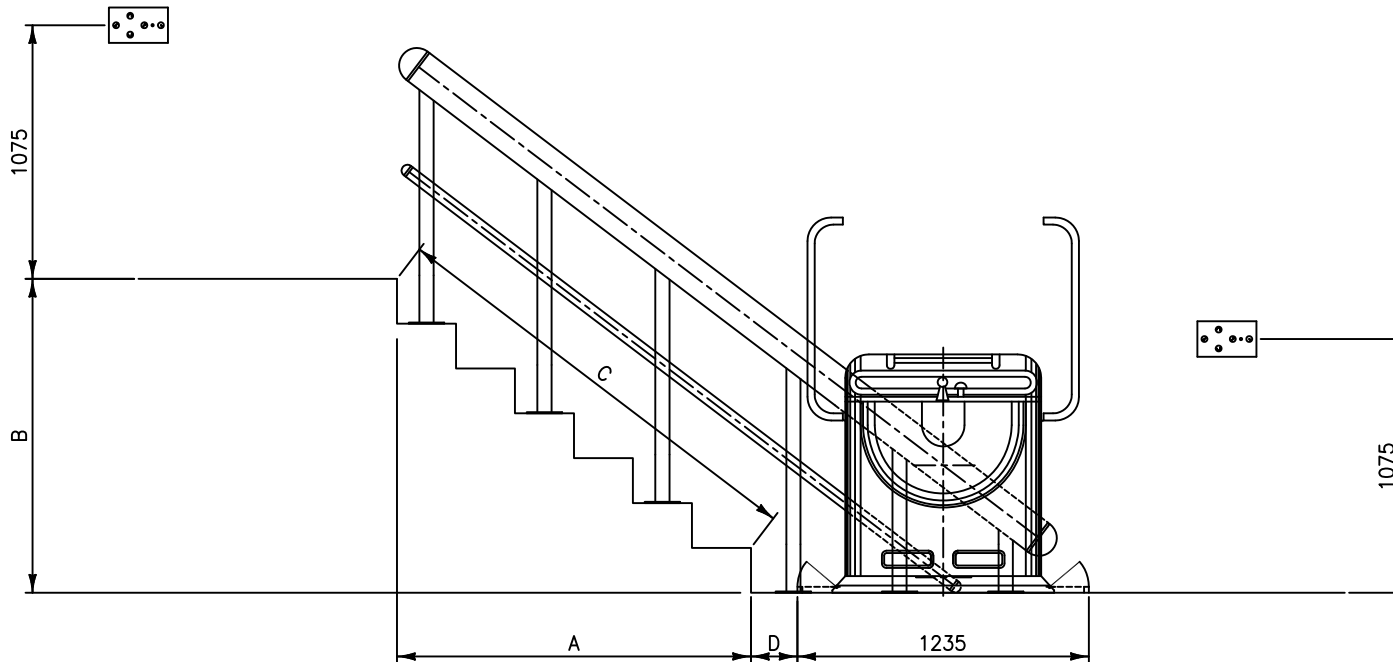
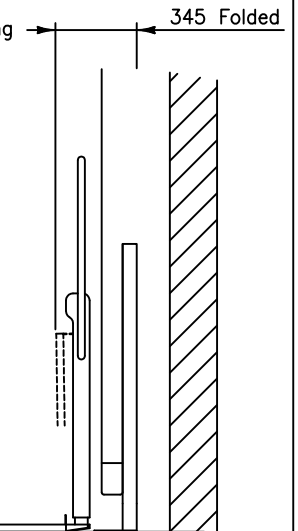

Issued for information only
 Do Not Use for Construction

BY	DATE	ISSUE	MODIFICATION	CHECKED
TMP	30.11.18	B	Redrawn	

INCLINED PLATFORM LIFT 900 X 750 PLATFORM GENERAL ARRANGEMENT RIGHT HAND STANCHION MOUNTED

NICHE LIFTS Ltd		DRAWN BY	DATE	CHECKED	SCALE
Do not scale this drawing. All dimensions in millimetres		TMP	2.5.07		1:25
		DRAWING NUMBER			
		1175/B			