

Goods Lift



- **Up to 15 metres Travel**
- **Self Supporting Structure**
- **Minimal Pit Required**
- **Variable Car Sizes**
- **Robust Design**
- **300-1000kg Load Capacity**

Niche..... Our passion and purpose is the supply of specialist lifts that enable wheelchair users and the less able gain access to upper floors and up stairways, plus service, trolley and goods lifts for transporting goods in the range 5kgs to 1000kgs

We supply, install and service Niche products that meet your specific needs.

NICHE LIFTS—Focus and expertise working uniquely for YOU on Niche Products.

Goods Lift

Model Type	Goods lift
Rated Load	300-1000kg capacity.
Rated Speed	0.1 m/s
Drive Type	Chain drive, machine above
Number of Stops	Up to 6 stops
Power Supply	415v, 3 phase, 50hz, 4-wire
Travel	Up to 15 metres
Pit	270 mm
Headroom	Door Height + 1300 mm
Car	Galvanised car with safety gear. Option of drop bar or lattice gate for car load protection.
Car Size	1000 wide x 1400 deep with single hinge doors, or 1275 wide x 1500 deep with double hinge doors. Car height 1200-2000. Note car protection restricts car internal depth and door opening widths. See layout data below. Variable dimension car available on request.
Controls	Call and send buttons at each landing. Lift in use, car position indicator and door open buzzer at each landing.
Configuration	Single entry or through car.
Door Type	Single or double swing hinge doors on landings depending on the model. Galvanised finish. Shutter gates available on request.
Shaft Enclosure	Standard freestanding structure clad by others. Note structure requires horizontal ties to the building fabric. Galvanised non fire rated cladding can be provided
Special Items	Light & socket in the machine room, lift arrival buzzer, lift out of use indicator and stainless steel machine room access door.
Compliance	EN81.3 EC Machinery Directive 98/37/EC
Documentation	Owners guide issued on completion.



Landing Door Type	Car Internal Depth				Door Opening Width			
	With Drop Bar		With Lattice Gate		With Drop Bar		With Lattice Gate	
	Front Opening	Through Car	Front Opening	Through Car	Front Opening	Through Car	Front Opening	Through Car
Single Hinge Door	1350	1300	1275		950		900	
Double Hinge Door	1450	1400	1400		1225		1150	

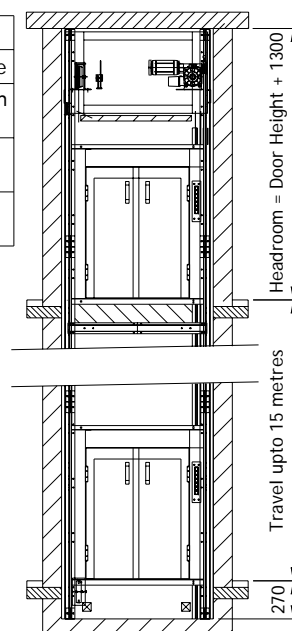
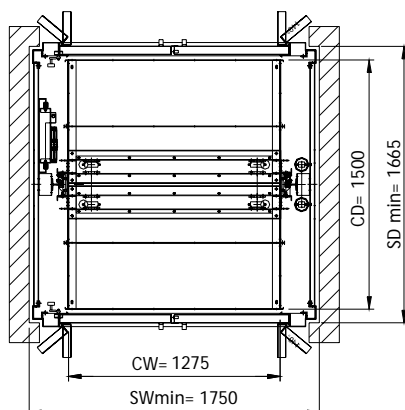
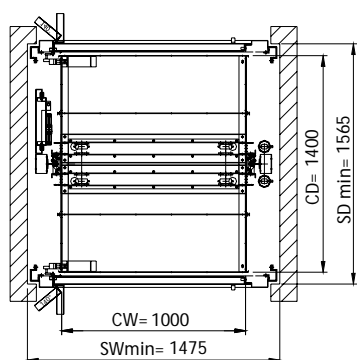

Configure your lift on-line at www.nichelifts.com

The information contained in this brochure was correct at the time of printing, due to continued development of our products we reserve the right to change the specification without prior notice

Lifts
NICHE

Niche Lifts Ltd
82 St Georges Road West
Bromley
Kent
BR1 2NP

Tel 020 8295 2852
Fax 020 8467 1044

www.nichelifts.com